

The Glycol Heat Trace System utilizes waste heat from the MX-CHP to provide hot fluid for heat trace ensuring your critical components are kept from freezing during the harshest cold days of winter.

KEY FEATURES:

- ✦ Up to 9.0 kW (30,700 BTU/Hour) heat when paired with the MX Generator
- ✦ Simple start-up control
- ✦ Built in pre-heat system, built in heaters for cold ambient startup
- ✦ 8 gallon insulated reservoir
- ✦ Rotary vane pump with variable flow 5-9.8 LPM (1.3-2.6 GPM)



SPECIFICATIONS

HEAT OUTPUT

Min. 5.1 kW (17,700 BTU/Hour)
 Max. 9.0 kW (30,700 BTU/Hour)

RATED TEMPERATURES

Inlet 60°C (140°F) Outlet 70°C (158°F)
 Max. 80°C (176°F)

PUMP SPECIFICATION

Adjustable flow rate 5.0-9.8 LPM (1.3-2.6 GPM)
 10-micron Filter and 200 mesh suction screen to protect pump.

HEAT TRACE DISTANCE

670m (2200ft*)
 *Assuming 1/2" ID Tubing, 50/50 glycol water mix at 8.3 LPM (2.2 GMP)

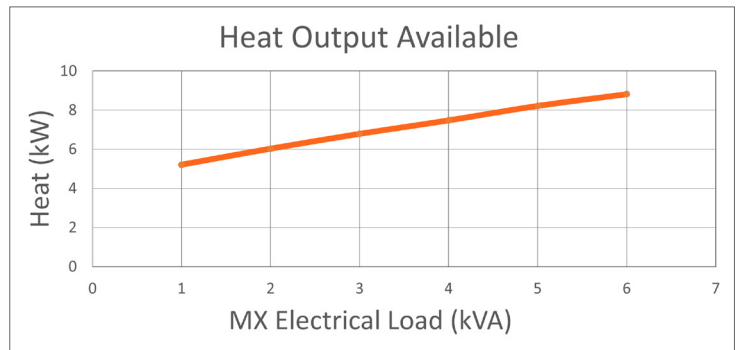

ENVIRONMENTAL

Contact GPT for operating conditions below -40°C or above +40°C.

AMBIENT OPERATING TEMPERATURE

Max. +40°C (104°F)
 Min. -40°C (-40°F)

COLD AMBIENT STARTUP

Cold startup at -40°C requires a pre-heat of 25 minutes to allow the VFD, pump, and motor to warm up.

CONSTRUCTION & MAINTENANCE

CONSTRUCTION

Standard outdoor enclosure, "Reach-in" design
 Weight: 400lbs. (182 kg)

MAINTENANCE INTERVAL

Annual

ELECTRICAL REQUIREMENTS

INPUT VOLTAGE

120/208 V 3-PH 60 HZ
 120/240 V 1-PH 60 HZ

POWER REQUIRED

950-1300 W*
 *Load is dependent on site ambient conditions and length of heat trace lines.

COMMUNICATIONS

DRY CONTACT AND LED'S

Run status
 Low return temperature
 Low tank level interlock and shut down

CERTIFICATIONS



CONFORMS TO UL 508A:2018 & CERTIFIED TO CSA C22.2 #286:2023

Specification data stated within this document is subject to change without notice. For more information, contact your GPT sales representative.

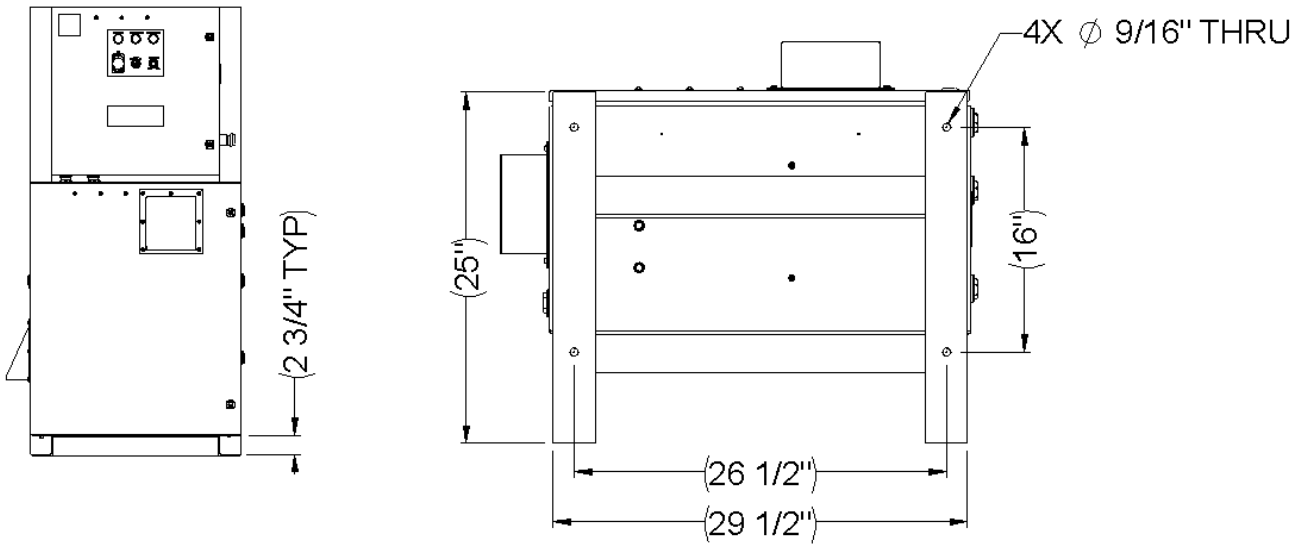

304459-3 REV2

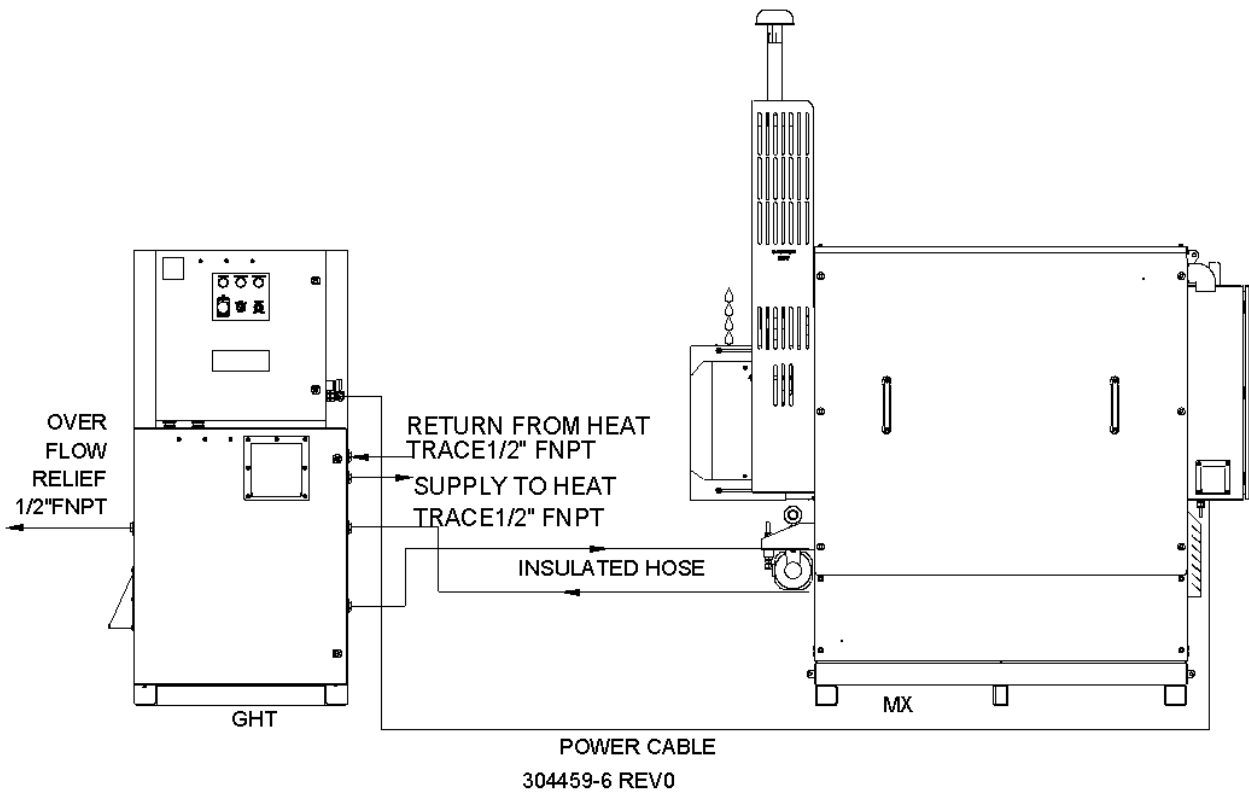

Specification data stated within this document is subject to change without notice. For more information, contact your GPT sales representative.